

Hazard Illumination and Projection Datasheet

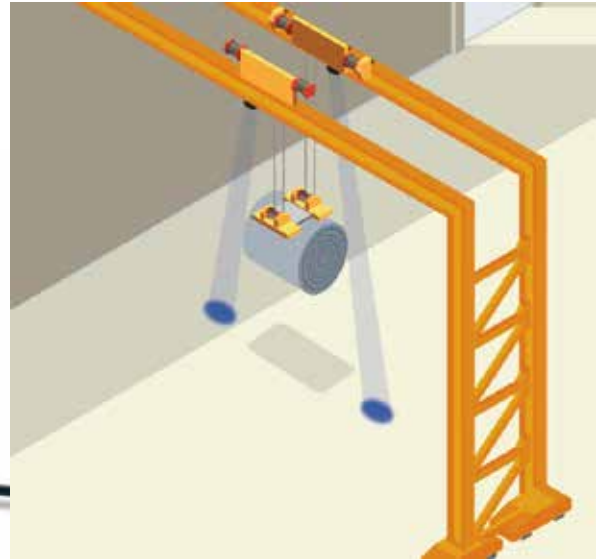

Overview:

SafetyCast™ Systems are the ideal solution for adding bright, visual warnings in areas where conventional wall and floor markings are easily missed or obstructed. Floor spot projections are perfect for heavy traffic areas that do not show markings in certain lighting conditions or due to wear. A line or spot projection outlines a safety warning around heavy equipment and machinery where additional safety is required.

Key Features:

- Easy to install on any overhead crane or forklift
- Adjustable mounting bracket allows for easy positioning of the beam
- High visibility illuminated projections provide the pedestrian with clear knowledge of their proximity to the overhead load
- Weatherproof and ideal for indoor/outdoor use
- Run off 10-80VDC
- Long operating life of 30,000+ hrs

Specifications:

Projection type:	Spot
Color:	Blue / Red
Power:	27W
Projection Fan Angle:	6°
IP rating:	65
Standard Warranty:	12 months
Weight:	2.3 Kg (5.07 lb)
Operating Temperature:	0° to 120°F (-20° to 50°C)
Working Lifetime:	30,000+ Hours
Input Voltage:	10-80VDC
Package Includes:	LED projector and adjustable mounting bracket

Hazard Illumination and Projection

Dimensions:

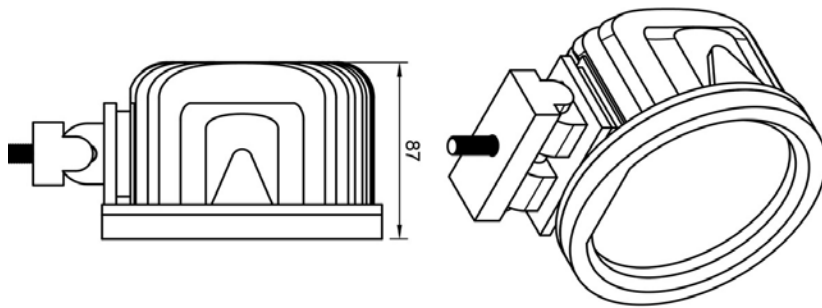
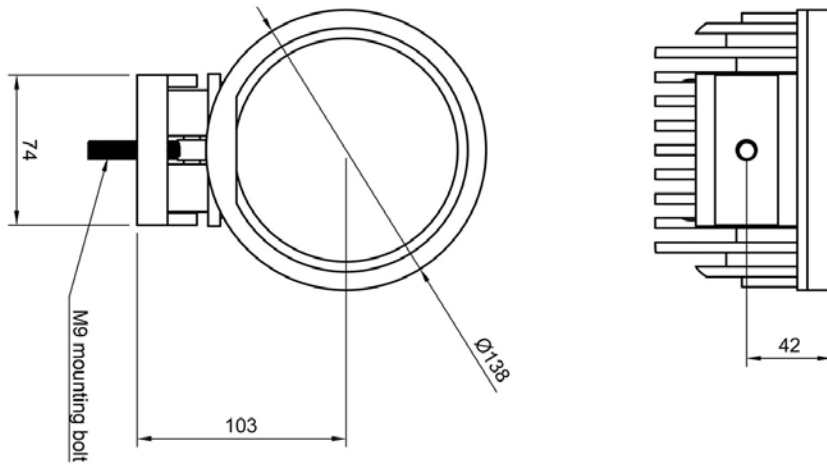



www.laserglow.com

For more information please contact:

LASERGLOW TECHNOLOGIES

99 Ingram Dr. Unit B, North York, ON, Canada M6M2L7

Tel. (416) 729-7976 Fax (480) 247-4864

sales@laserglow.com

E&OE: Data included in this sheet may be subject to change without notice.
Please confirm critical specifications with our staff prior to ordering.